

The GEOMON 4D electrical monitoring system: current state and future developments

ROBERT SUPPER¹, ALEXANDER RÖMER¹, GERHARD KREUZER², BIRGIT JOCHUM¹, DAVID OTTOWITZ¹, ANNA ITA¹ and STEFANIE KAUER¹

¹ Geological Survey of Austria, Neulinggasse 38, 1030 Wien, Austria.

² LIFTOFF, Kölblgasse 11/1, 1030 Wien, Austria.

Robert.Supper@geologie.ac.at

Introduction

In 2000, after the Geophysical Department of the Geological Survey of Austria had successfully applied the geoelectric method to investigate the structure of the large landslide of Rindberg near Sibratsgfall (JARITZ et al., 2004; SUPPER et al., 2009), the Torrent and Avalanche Control Vorarlberg contracted the Geological Survey of Austria to develop a permanent geoelectrical monitoring system for landslides. At that time it was found that most of the commercially available systems were optimised to perform conventional investigation surveys and at that time none of the systems could fulfil the requirements of permanent geoelectric monitoring (high resolution, high speed of data acquisition, high reliability, recording of full signal samples for noise detection, remote controlled maintenance and automatic data transfer). Therefore, in late 2000 the design of an innovative system was started (SUPPER and RÖMER, 2003). The first 29-electrode prototype was installed to observe the mudflow of Rindberg near Sibratsgfall in spring 2002, where it was continuously measuring since that time till the end of 2007 with a few unforeseen interruptions due to lightning strokes. Based on the results gathered during operation of the prototype, the system was redesigned and optimised for monitoring purpose as well as for “conventional” field surveys within the following years and finally reached its maturity state in 2006. At the end of 2007 after 5 years of operation, the maintenance of the system at Sibratsgfall was abandoned since a significant part of the cables had been cut due to large displacements.

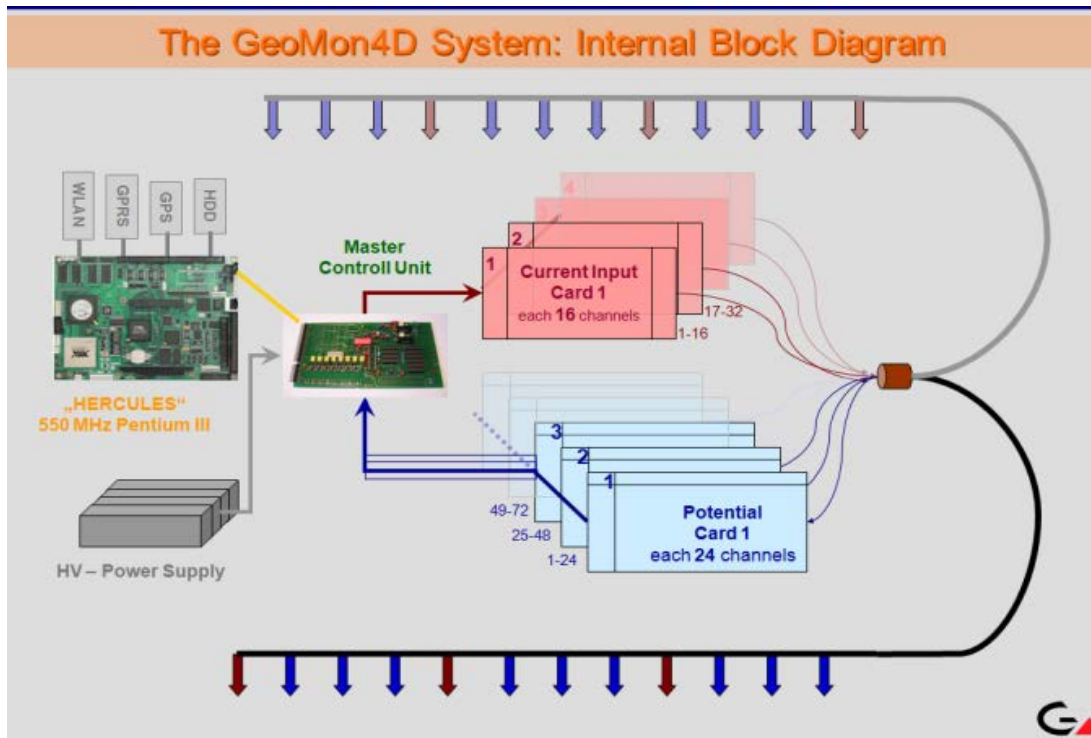

Fig. 1: Architecture of the GEOMON4D system.

The GEOMON 4D System

The GEOMON4D instrument, as it is today, is based on technically mature components and offers a completely open architecture, allowing installation of any number of current or potential electrodes by adding parallel or serial cards (cp. Fig. 1). The principal characteristics are the high speed of data acquisition (approx. 3000 measurements/hour in single channel mode) and recording of the full signal (usually 1000 samples per single configuration) for noise analysis and filtering.

Since the hydrological processes which could lead towards triggering of a landslide could be built up gradually or sudden, our monitoring system for surveillance of these processes is capable of surveying long period changes (within months; e.g. permafrost related phenomena) as well as short sudden impacts (within minutes or hours; e.g. strong rainfalls). It provides a point shot of the current status of the subsurface, which practically means, that data acquisition time has to be much less than the period of expected changes. The instrumentation provides high resolution data, by keeping the error of each single measurement low (e.g. by selecting only measurements with a low noise content for further processing) and by using many different electrode configurations, which visually means to "illuminate" each subsurface block from as many different direction as possible and to sample its "shadow". The data set produced shows a high reliability and is used as an additional tool for local authorities to decide about timely warning. The possibility of repeating the measurements at short time intervals allows verifying anomalous trends.

Most areas under observation are usually not easily accessible, but data sets have to be regularly processed. Therefore the possibility of remote maintenance and automatic data delivery by email is essential and consequently GPRS (General Packet Radio Service) data transfer was implemented. Maintenance can be performed fully remote-controlled and data (measurement

results, test sequences and log files, containing information about system and GPRS connection status) are sent automatically via email to the data processing centre. Consequently, immediate availability of information for local stakeholders can be guaranteed, which is very important in the case of sudden hazards like mud flows. The general layout of the remote control network is displayed in Figure 2.

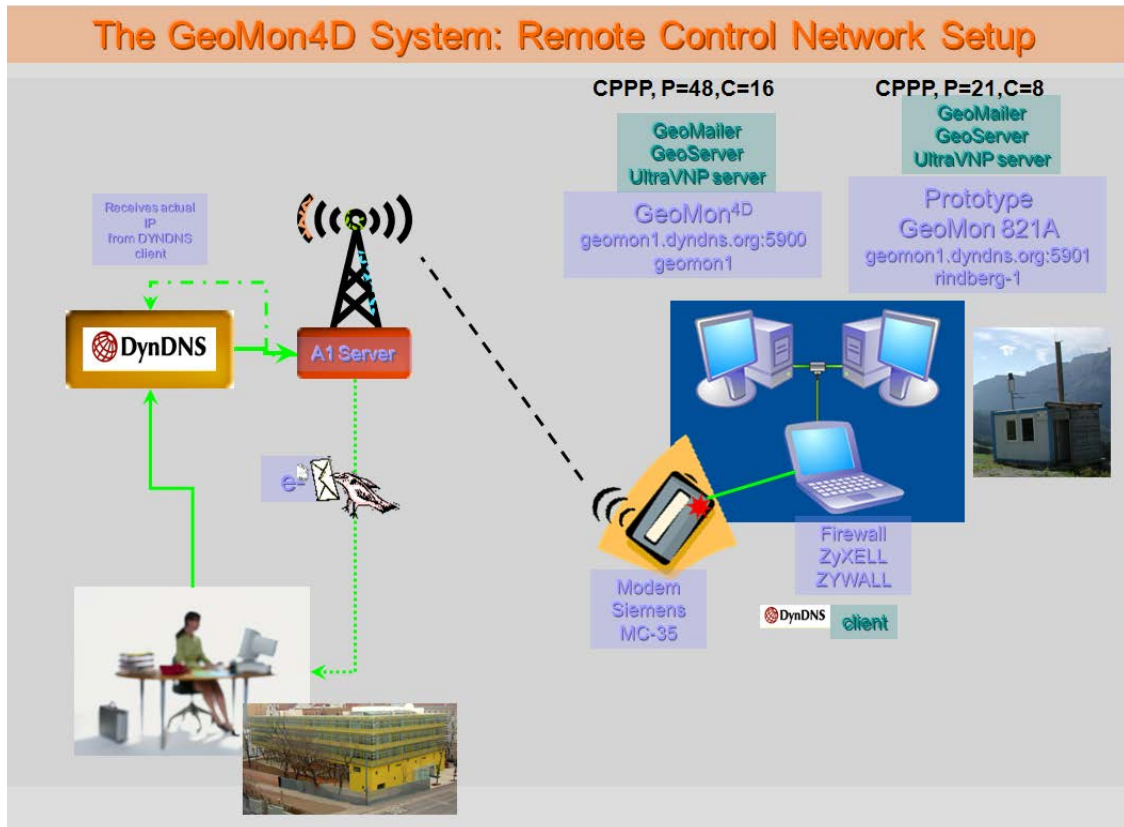

Fig. 2: Diagram explaining the setup of the remote control network.

Further Requirements

A big challenge in geoelectric monitoring is the assurance of power supply. To use the local power grid proved to be unreliable and very expensive (500 m cable cost about 14,000 Euro). Therefore, fuel cells were chosen for power supply, being less expensive, mobile (a fuel cell can be transported from an abandoned monitoring site to a new site), and very reliable. The fuel cell is driven by methanol, whereas the respective methanol tanks have to be changed about every 8 months.

Furthermore, the optimum way of installing the arrays (surface, trenches, different kinds of cables and connectors) was tested over years and a lightning protection device for multi-core cables had to be developed. It proved to be useful, in terms of persistence and maintenance, to dig cables and electrodes if this was possible.

The necessity to monitor landslide stability conditions has induced C.S.G. (Centro Servizi di Geingegneria, Italy) to develop an innovative multiparametric monitoring system of stability called D.M.S. (patent pending and trade mark C.S.G. S.r.l.). This device measures with high accuracy and precision displacements in 2 or 3 directions (both horizontal and vertical at all the prefixed depths), piezometric water levels and soil temperature, thus allowing the complex

analysis of dynamics of any landslide, e.g. deformation analysis, movements, sliding surface's depths or piezometric variations (FOGLINO et. al., 2006). In late 2009, both innovative technologies (geoelectric monitoring and DMS) were coupled for the first time on the landslide of Gschliefgraben and they are operating since then without any failure.

Future Developments

Currently six Geomon4D instruments are operating simultaneously for monitoring purposes on different landslides in Austria, Italy and France and two instruments are permanently used by the staff of the Geological Survey of Austria for usual tomographic surveys. The results from our monitoring sites have shown that there is a critical lack of inversion routines that could handle permanent monitoring data. Some commercial codes (RES2DINV and AGI EarthImager) were tested but did only partially lead to satisfying results. Therefore future developments will focus on 4D Inversion (in cooperation with Jung-Ho KIM from KIGAM, Korea), data correlation and interpretation. At the end of 2012 a completely redesigned version of the Geomon4D system will be available incorporating all the experience gathered from the operation of the TEMPEL monitoring network between 2009 and 2012.

Acknowledgements

The development of the Geomon4D prototype system was financially supported by the Torrent and Avalanche Control (WLV), Section Vorarlberg, the county of Vorarlberg and internal funds of the Geological Survey of Austria in frame of the Bund-Bundesländer-Kooperation (project VC-07). Further developments were financed by internal funds of the Geological Survey of Austria and by funds coming from the 7th FP project "SafeLand – Living with the landslide risk in Europe" and from the project "TEMPEL - **Temporal** changes of **geo**electrical properties as possible indicator of future failure of high risk landslides", funded by the Austrian Science Fund (FWF)-TRP 175-N21 in frame of the Translational Brainpower Program. Additional financial support was given by the Central Institute for Meteorology and Geodynamics (ZAMG) for developing the lightning protection. We acknowledge the support of A. Reiterer, Torrent and Avalanche Control (WLV), Section Vorarlberg, who had the idea to apply the geoelectrical technique for landslide monitoring and initiated the funding for the prototype system and G. Hübl, who shared our minds in the pioneer times of the Geomon4D.

References

- FOGLINO, L., LOVISOLO, M. and DELLA GIUSTA, A., 2006: Contribution of DMS monitoring systems in the analysis of slide micro-movements for early warning management, risk assessment and evaluation of mitigating actions. – Geophysical Research Abstracts, Vol. 8, 06122, Vienna.
- JARITZ, W., REITERER, A. and SUPPER, R., 2004: Landslide Rindberg (Vorarlberg): Multidiscipline Research. – Proceedings of the 10th Interpraevent Congress, Riva del Garda.
- SUPPER, R. and RÖMER, A., 2003: New Achievements in Developing a High Speed Geoelectrical Monitoring System for Landslide Monitoring. – Proceedings of the Environmental and Engineering Geophysical Society, 9th Meeting Prag, Prag.
- SUPPER, R., RÖMER, A. and JOCHUM, B., 2009: Geoelectrical measurements for natural hazard monitoring. – SEGJ 9th International Symposium, Extended Abstracts, Sapporo.