

The Structural Development of Early Mesozoic Coccoliths and its Evolutionary and Taxonomic Significance

By PAUL RICHARD BOWN*)

With 5 Figures and 3 Plates

Austria
Britain
Jurassic
Calcareous Nannofossils
Evolution
Taxonomy

Contents

Zusammenfassung	33
Abstract	33
1. Introduction	33
2. Previous Works	34
3. Study Areas	34
3.1. B.G.S. Mochras Borehole, North Wales	34
3.2. Alpine Sections	34
4. Coccolith Morphology	34
5. Coccolith Structure	34
5.1. Structural Groupings	35
5.1.1. Loxolith Rim Structure Group	35
5.1.2. Protolith Rim Structure Group	35
5.1.3. Radiating Placolith Rim Structure Group	37
5.1.4. Imbricating Placolith Rim Structure Group	37
5.2. The Structural Groups in a Stratigraphic Context	37
6. Lineages and Evolution	37
7. Comparison with Earlier Studies	42
8. Coccolith Taxonomy	42
9. Conclusion	42
10. Systematic Palaeontology	43
Acknowledgements	44
References	44

Zusammenfassung

Die genaue elektronenmikroskopische Strukturanalyse von obertriassischen und unterjurassischen Coccolithen aus Österreich und Großbritannien hat das Vorhandensein von mehreren fundamental verschiedenen Coccolithenbauplänen gezeigt. Es werden vier verschiedene Strukturgruppen von Coccolithen unterschieden, benannt und definiert; zwei davon sind bereits in den ältesten bisher bekannten Coccolithenvorkommen in der Obertrias (Nor) vorhanden, während die beiden anderen später, in einer Zeit mit schneller Diversifikation, im frühen Jura (Pliensbach), erschienen. Die entwicklungsgeschichtliche Bedeutung und die Komponenten dieser vier Hauptkomponentengruppen werden besprochen und mit früheren Bearbeitungen, vor allem durch PRINS (1969) und JAFAR (1983) verglichen. Die Relevanz von detaillierten strukturellen Untersuchungen in der Coccolithentaxonomie und die fundamentale Bedeutung der Struktur des Randes, wie sie in den frühen Coccolithen erkennbar ist, werden diskutiert.

Abstract

Detailed structural analyses of Upper Triassic and Lower Jurassic coccoliths from Austria and Great Britain, using the scanning electron microscope, has revealed the presence of

several fundamentally distinct modes of coccolith construction. Four major "coccolith structural groups" are recognised, named and defined; two of these are present in the earliest known coccolith assemblages, in the Upper Triassic (Norian) and two appear at a later time of rapid diversification in the Lower Jurassic (Pliensbachian). The evolutionary significance and the components of these four major groups are reviewed and compared to previous related work, notably by PRINS (1969) and JAFAR (1983). The importance of detailed structural analysis in coccolith taxonomy and the fundamental importance of the rim structure as revealed by early coccoliths are discussed.

1. Introduction

This paper represents a preliminary attempt to interpret the results gained from detailed observational studies of calcareous nannofossils taken from several Upper Triassic and Lower Jurassic sections in Britain and North-west Europe. The project was initiated as a straightforward re-investigation of important Lower Jurassic sections in Britain and North-west Europe in order to improve existing biostratigraphic schemes and to investigate early coccolith evolution and palaeoceanography. The appearance of publications by

*) Author's address: PAUL RICHARD BOWN, Postgraduate Unit of Micropalaeontology, Department of Geology, University College London, Gower Street, London WC1E 6BT.

MOSHKOVITZ (1982) and JAFAR (1983), both reporting the occurrence of calcareous nannofossils and more importantly coccoliths from the Upper Triassic prompted the extension of our project aims to encompass the earliest appearances of coccoliths and thus the inclusion of Triassic sections. To this end the sections chosen were the B.G.S. Mochras borehole, Wales, providing the longest complete Lower Jurassic sequence in Europe, and several sections from the Austrian, German and Italian Alps covering most of the Triassic stages in the area thought most suitable for coccolith study.

Observation of the nannofossils was carried out using standard light microscopy and scanning electron microscopy. As the work proceeded it became clear that detailed structural analysis of the coccoliths was revealing interesting trends in coccolith morphology. This paper aims to describe and expound upon the morphological observations gained by the scanning electron microscope study, including the naming and definition of several distinct structure groups. Their evolutionary significance at this early stage in coccolith development is also considered, together with the importance of such studies in coccolith taxonomy.

2. Previous Work

Previous literature on pre-Jurassic nannofossils is thoroughly reviewed by JAFAR (1983) and the only work omitted was that of MOSHKOVITZ (1982) which appeared at the same time. Around thirty papers have included relevant information concerning Lower Jurassic nannofossils but only the paper by PRINS (1969) included any evolutionary treatment and this will be discussed later in the paper.

3. Study Areas

3.1. B.G.S. Mochras Borehole, North Wales

The Mochras borehole is situated three kilometres west of Llanbedr in North Wales. The borehole passed through and cored 1305 m of Lower Jurassic strata, from which 366 samples were taken for this study. The section consists of well-lithified, grey and black marine argillites and subordinate limestones. The lowest Lower Jurassic rocks from the borehole appear to be of shallow water origin, however, the remainder of the section is a zonally complete and sedimentologically monotonous sequence, evidently the result of consistent and considerable subsidence towards the middle of a basin of accumulation which is now beneath Cardigan Bay (WOODLAND, 1971).

3.2. Alpine Sections

The alpine material was collected from seven published sections, all but one falling within the Northern Calcareous Alps of Austria and Southern Germany. The Northern Calcareous Alps comprise a large, east-west trending structural unit which is relatively unmetamorphosed and non-metamorphosed. The unit contains thick, dominantly Triassic carbonate successions representing a region of deposition originally on the northern edge of

the Tethys ocean. The area can be further divided into three east-west trending facies belts:

- a northerly shallow lagoonal basin (Hauptdolomit facies);
- a median, marginal reef platform (Dachstein facies) and
- a southerly open ocean basin (Hallstatt facies).

Samples were collected from all Triassic stages and from across the three facies belts as follow:

- 1) Pass Lueg – Dachstein limestone (Dachstein facies) – Norian–Rhaetian.
- 2) Fischerwiese – Zlambach marls (Hallstatt facies) – Rhaetian.
- 3) Kendelbachgraben – Kössener Schichten (Hauptdolomit facies) – Rhaetian–Lower Jurassic.
- 4) Weißloferbach – Swabian and Kössener Schichten (Hauptdolomit facies) – Norian–Rhaetian.
- 5) Ofenbach – Dachstein facies – Upper Anisian.
- 6) Lehenmühlengraben – Werfener Schichten (Dachstein facies) – Upper Skythian.
- 7) Picolbach (Southern Calcareous alps) – Cassianer Schichten – Ladinian/Carnian.

Coccoliths were found to be present only in material from the Weißloferbach and Fischerwiese sections (Norian and Rhaetian) and in each section they were a minor component of an otherwise abundant assemblage of *Conusphaera mexicana* and *Prinsiosphaera triassica*. The coccoliths found are described by BOWN (1985).

4. Coccolith Morphology

Coccolith morphology is the basis for our system of classification and the terminology used for its description is crucial for its accurate and clear communication. Such descriptive terminology has gone through many stages and adaptations as observational techniques have improved, but there still remains much ambiguity and a lack of consistency in the description of fossil coccoliths. It would seem logical to look in detail at the ultrastructure of the earliest known coccoliths and to apply terms and definitions to their relatively uncomplicated structures which can then be adapted, and supplemented for new structures that emerge as the coccolithophores diversify through time.

5. Coccolith Structure

The coccoliths observed from the Triassic and Lower Jurassic all possess a relatively simple overall structure consisting of a high, elliptical ring of calcite elements enclosing a central area which may be variously bridged by bars and crosses. The elliptical ring which encloses the central space will be referred to as a rim (= margin). A rim may consist of more than one ring of elements in the same (horizontal) plane and such concentric rings of elements are called cycles. The rim may also be constructed from more than one ring of elements in the vertical plane, i.e., superimposed on top of each other, and these proximal and distal components are referred to as shields.

Thus, coccolith structure essentially consists of a rim, which may or may not be a complex compound con-

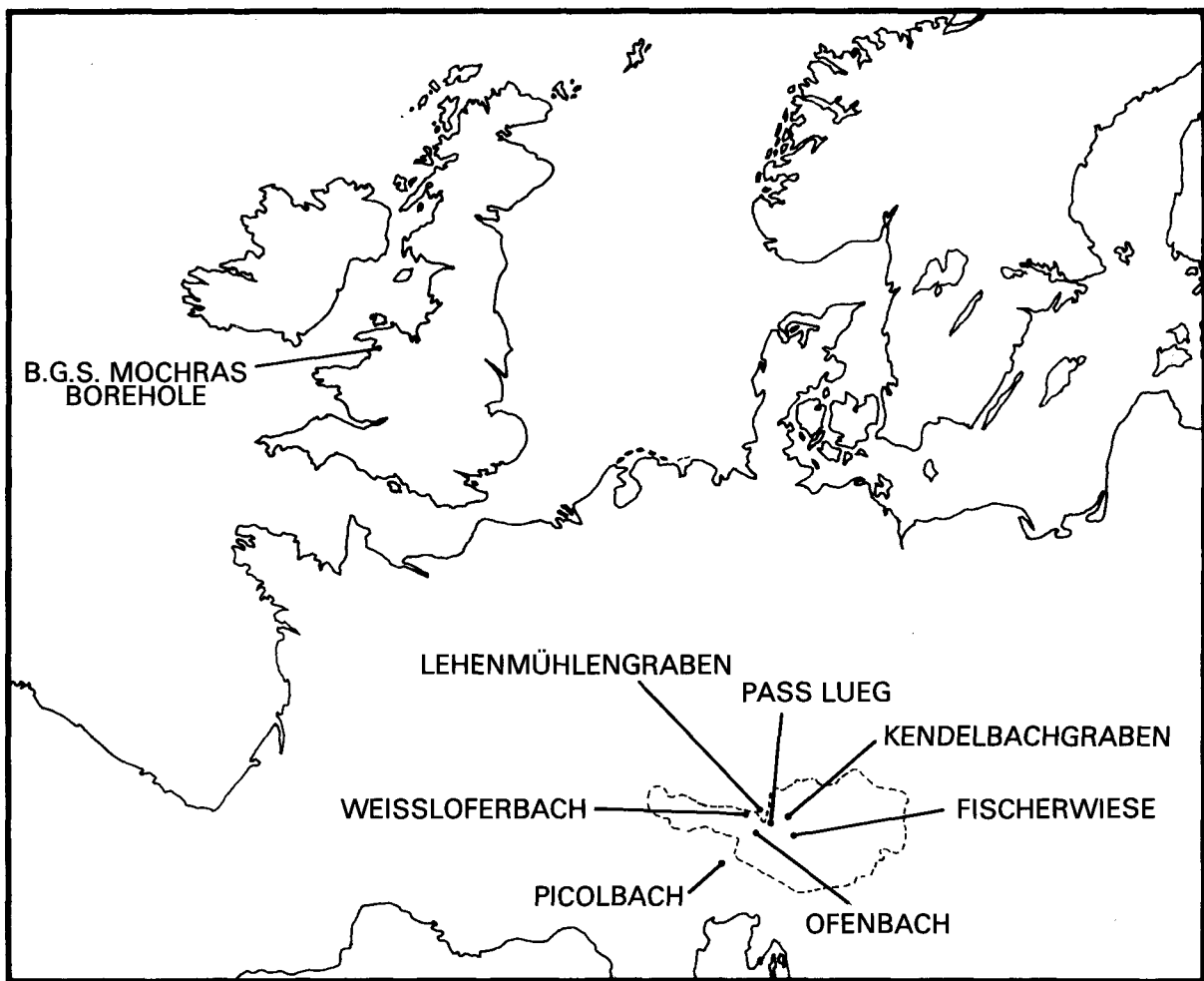

Fig. 1: Map showing the location of sampled sections.

struction, and a central area, which may or may not be filled or bridged by any of a large variety of structures.

5.1. Structural Grouping

In the present study, four major structural groups are recognised and each of these is illustrated and described in detail.

5.1.1. Loxolith Rim Structure Group

First used by NOËL (1965, p. 66) as a generic term and later by BLACK (1972, p. 19) as a more widespread structural term: a loxolith rim is a compound structure comprising a dominant distal shield cycle and a proximal shield with a vertical (distal) extension (Fig. 2):

- Distal shield
composed of narrow, steeply inclined, i.e., imbricating, laths which BLACK (1972, p. 19) likened to the staves of a barrel which had been given a sharp twist. This cycle is the dominant component of the loxolith rim and gives the structure its height.
- Proximal shield
composed of elements with a triangular cross-section which form a flat base to the coccolith with radiating sutures and also extend upwards, along a sloping boundary with the distal shield elements, to form an inner cycle to the distal shield, appearing as

tangential lathes lying on the inner surface of the distal shield elements and possessing vertical sutures. This vertical extension of the proximal shield is usually no greater than half the height of the distal shield outer cycle but does vary between species.

The loxolith rim is possessed by the genera *Zeugrhabdotus*, *Archaeozygodiscus*, *Crepidolithus*, *Tubirhabdus* and *Staurorhabdus*.

5.1.2. Protolith Rim Structure Group

A term defined here for the first time: a protolith rim is a compound structure comprising a dominant distal shield cycle and a proximal shield with a vertical (distal) extension (Fig. 2):

- Distal shield
composed of thin rectangular elements arranged tangentially to an ellipse and joined along sutures which are perpendicular to the coccolith base, i.e., showing no imbrication. The shield is often tall and stands vertically to sub-vertically. Using the analogy of BLACK (1972) referred to above, the outer distal cycle may be likened to an undisturbed barrel with broad staves.
 - Proximal shield
identical to that of the loxolith rim group.
- Variations in particular element dimensions are common between species but the basic protolith rim is pos-

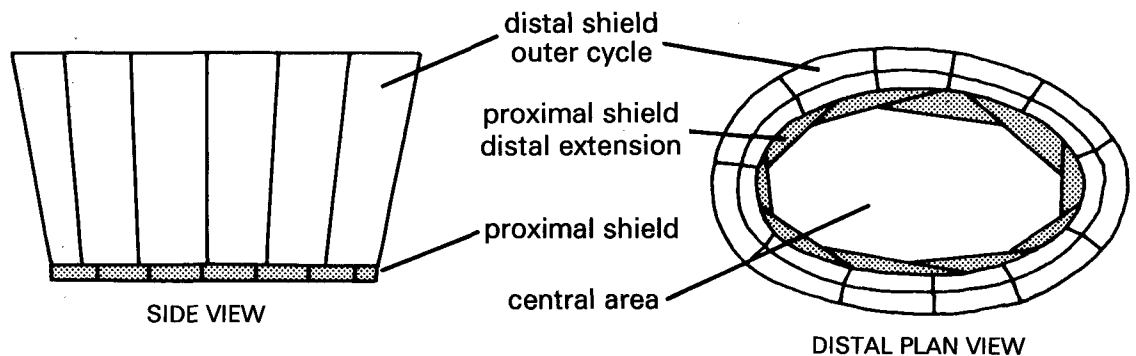

PROTOLITH RIM STRUCTURE

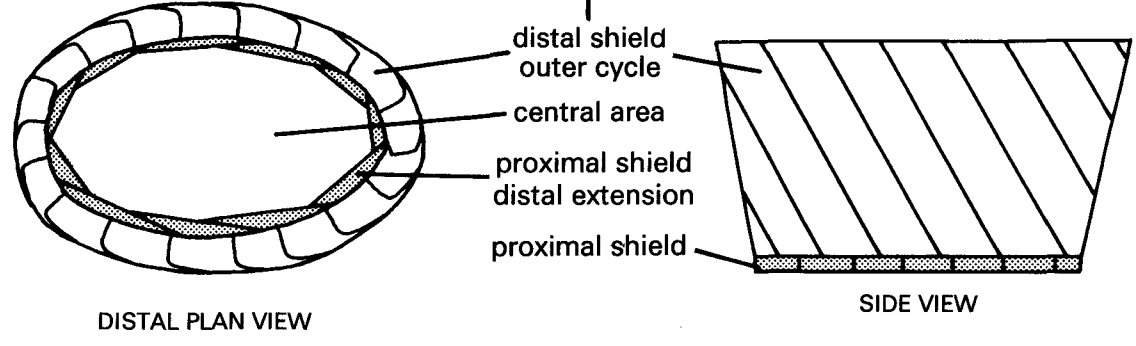
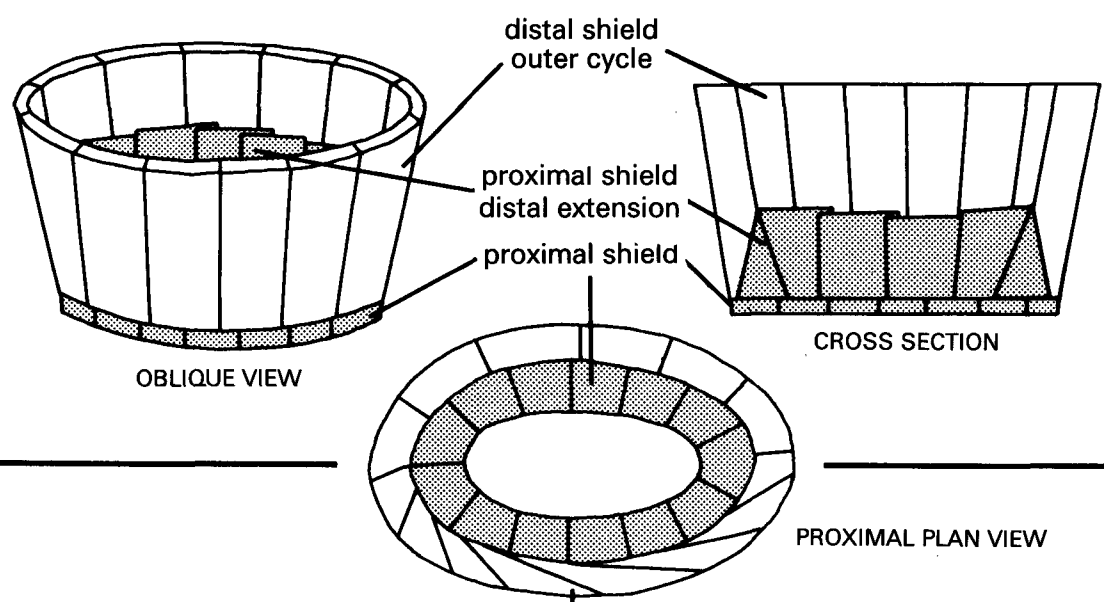

LOXOLITH RIM STRUCTURE

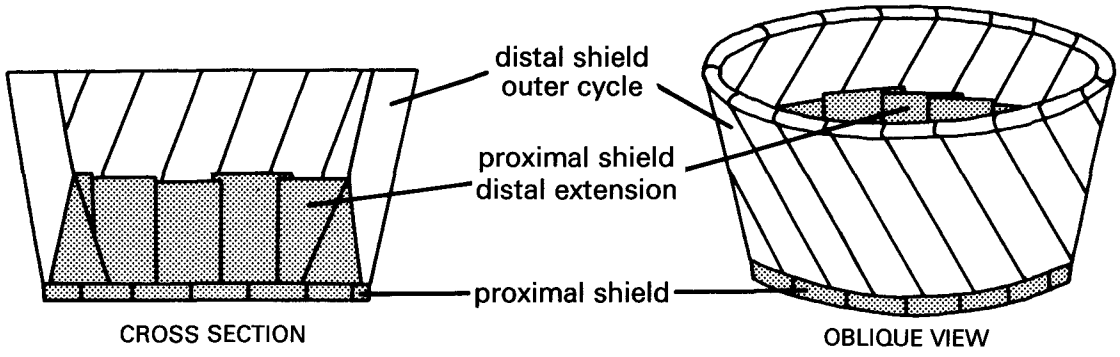

Fig. 2: Schematic diagram illustrating the characteristic features of the loxolith and protolith rim structure groups.

sessed by the genera *Crucirhabdus*, *Parhabdolithus*, *Mitrolithus* and *Stradnerlithus*.

Comparison of the protolith rim and the loxolith rim shows all the component parts to be analogous, with the imbrication of the outer distal cycle being the feature that divides them. In most of the cases encountered so far the two rims are readily divisible when observed in side view using the scanning electron microscope. However, the genus *Crepidolithus* appears to include coccoliths which display both protolith and loxolith rim features. For example, most published illustrations of *Crepidolithus cavus* show it with a typical loxolith rim structure (GOY, 1981, pl. 6), whereas *Crepidolithus crassus* is often illustrated with vertical elements (NOËL, 1965, p. 85) but also with a loxolith structure (CRUX, 1984, fig. 11.2). Thus, at present *Crepidolithus* is a problematic genus but is included in the loxolith rim group here, as all those specimens observed during this study possessed steeply inclined elements (Pl. 1.2).

The Pliensbachian stage of the Lower Jurassic saw the first appearance of the coccolith structure termed placolith. A placolith consists of two usually broad concavo-convex discs or shields, one lying on top of the other and connected by a central pillar or tube. The term wall will be employed to describe vertically orientated rings of elements which transcend the division of proximal and distal.

The placolith structure marks a profound change in coccolith construction with the elements forming broad and very short, i.e., thin, shields in the horizontal plane as opposed to the earlier tall, thin and upright rims which were vertically orientated. The proximal shield also expands greatly to become a major part of the rim construction.

It is also important to note that the development of the placolith structure allowed the first physical locking together of individual coccoliths on the cell surface to form a preservable coccosphere, as opposed to a presumed organic bond mechanism which had previously held and still holds the loxolith and protolith coccoliths to their respective cells.

5.1.3. Radiating Placolith Rim Structure Group

A simple placolith construction comprising a proximal and a distal shield (Fig. 3):

- Distal shield
composed of blade-like laths lying side by side, their broad distal faces level and the suture lines between each element orientated radially to the coccolith centre. Most specimens show some kinking of one or more of the suture lines and these give the impression of a tendency towards suture precession, i.e., the twisting of the suture lines about the centre of the coccolith, departing from the radial pattern.

The elements slope gently outwards to form the shield and sharply inwards to form a deep central area. The earliest examples of this structure group, i.e., the genus *Biscutum*, possesses no other cycles in the distal shield, however, a number of Lower Jurassic forms do show the development of an inner distal cycle.

- Proximal shield
basically repeats the structure described for the distal shield but the suture kinking is more pronounced

and more consistent. The proximal shield is slightly smaller than the distal shield and fits fairly closely against the concave proximal face of the distal shield.

The rim structure described is the first and simplest placolith to appear in the N.W. European Early Jurassic and is seen in the genus *Biscutum*. Later radiating placolith structures usually show modifications to this basic pattern.

5.1.4. Imbricating Placolith Rim Structure Group

A complex compound placolith rim which consists of a distal shield with inner and outer cycles, a proximal shield and a connecting inner wall (Fig. 3):

- Distal shield, outer cycle
composed of blade-like laths which are imbricating, producing sutures which twist around the coccolith centre in an anti-clockwise direction.
- Distal shield, inner cycle
this cycle is subordinate to the broad, sloping outer cycle and is made of small "squarish" elements usually showing little or no lath imbrication and suture precession. This inner cycle lies over the inner edge of the outer cycle and the surface along which they meet appears to slope towards the coccolith centre.
- Proximal shield
imbrication appears to be absent in this shield and the elements interlock along more complex suture lines which show a pronounced kink similar to that seen in the shields of the previous structure group (5.1.3.). The proximal shield is only slightly smaller than the distal shield and they are usually separated by a distinct gap towards their outer edges.
- Inner wall
composed of small, "squarish" elements arranged vertically and lying side by side lining the central area and joining the proximal and distal shields.

This rim structure is possessed by the genera *Lotharingius* and *Ellipsagelosphaera*.

5.2. The Structural Groups in a Stratigraphic Context

The loxolith rim and protolith rim structure groups are both present in calcareous nannofossil assemblages which have yielded the earliest known true coccoliths (Late Upper Triassic). These two groups remained the only pattern for coccolith construction through the Late Triassic and Hettangian and Sinemurian stages of the Early Jurassic until the appearance of the radiating placolith rim and imbricating placolith rim groups in the early and late Pliensbachian respectively. The loxolith and protolith rim groups remain after the Pliensbachian but became only minor components of the coccolith assemblages, especially after the rapid numerical expansion by coccoliths of the imbricating placolith group which was maintained for much of the remaining Mesozoic.

6. Lineages and Evolution

When applying evolutionary ideas to coccolith studies we rely on the recognition of morphological trends

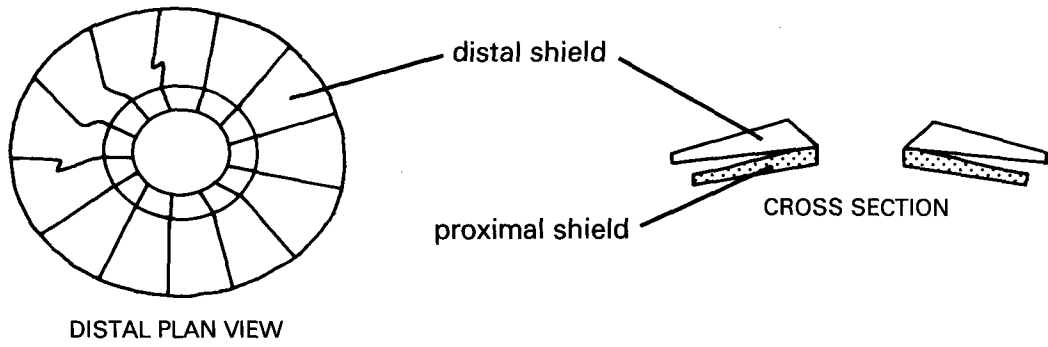

**RADIATING PLACOLITH
RIM STRUCTURE**

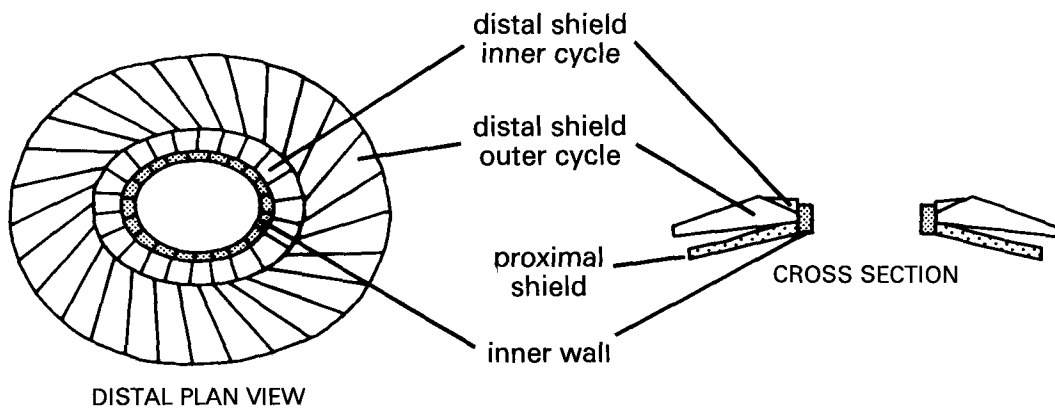
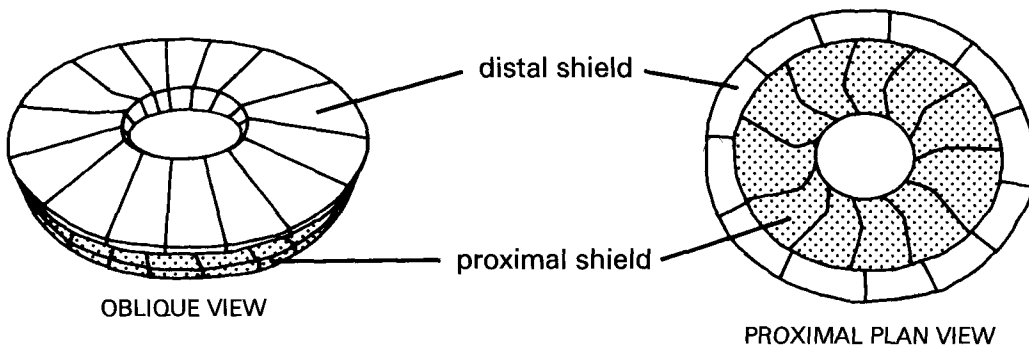

**IMBRICATING PLACOLITH
RIM STRUCTURE**

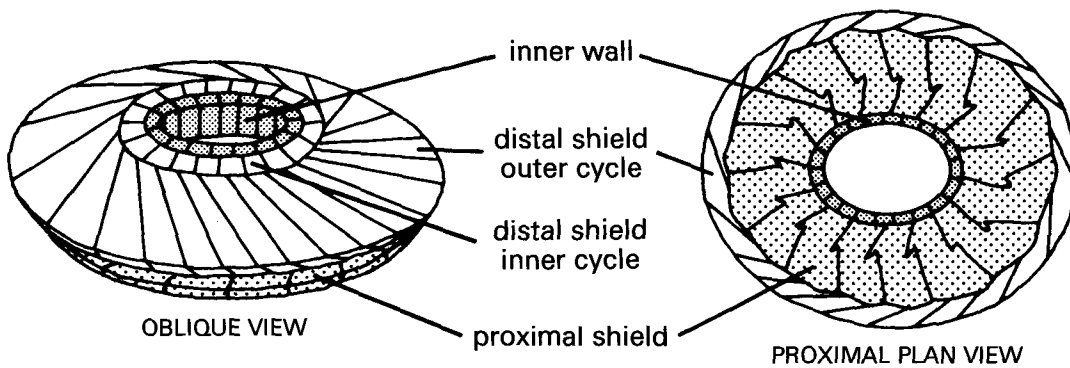

Fig. 3: Schematic diagram illustrating the characteristic features of the radiating placolith and imbricating placolith rim structure groups.

traced through time. The assumption that morphology is the phenotypic expression of the genotype is inherent in any such study. It follows that any study involving evolution and lineages must include the gathering of detailed and accurate morphological information. This can best be achieved using the scanning electron microscope.

The present study included the detailed structural analysis of Upper Triassic and Lower Jurassic coccoliths and it became apparent that several well-defined groups/lineages of coccoliths were present in this time interval, each one characterised by a unique style of coccolith rim construction. Further study revealed that these rim structure groups could be easily traced through time allowing the analysis of coccolith development for much of the Jurassic. It is apparent then that the coccolith rim structure is of fundamental importance when tracing the long-term development of coccoliths. The central area structures, however, show no such consistency in long-term evolutionary change and structures such as bars and crosses appear commonly and repeatedly in unrelated coccoliths.

In the Upper Triassic the two species of coccoliths present, *Crucirhabdus minutus* and *Archaeozygodiscus koessenensis*, represent members of the protolith rim and loxolith rim groups respectively. These two groups contain all the coccoliths present in the Lower Jurassic until further structural diversification occurs in the Pliensbachian.

The protolith rim lineage is made up of *Crucirhabdus minutus*, *Crucirhabdus primulus*, *Parhabdololithus liasicus*, *Parhabdololithus robustus*, *Mitrolithus elegans* and *Mitrolithus jansae* (*Calvascularis jansae*). Slight structural changes in the basic protolith pattern occur in the development of the genera *Stradnerlithus* and *Stephanolithion* in the upper Lower Jurassic and Middle Jurassic respectively.

The loxolith rim lineage is made up of *Archaeozygodiscus koessenensis*, *Tubirhabdus patulus*, *Zeugrhabdotus erectus*, *Crepidolithus crassus*, *Crepidolithus cavus*, *Crepidolithus plienschachensis* and *Staurorhabdus quadricellus*.

The radiating placolith lineage appears in the Early Pliensbachian and for the remainder of this stage provided a lineage from which a great variety of forms diversified. A simple form of *Biscutum* appears first in the Mochras borehole section, followed by many other coccoliths all possessing the diagnostic radiating placolith structure. These include species of *Biscutum*, *Discorhabdus*, *Sollasites*, *Axopodora*, *Ethmorhabdus*, and, with some greater modifications *Calyculus* and *Carinolithus superbus*. The aforementioned genera possess a radiating placolith rim structure which conforms to the basic pattern already described but many of them also include some additional structural developments which warrant further subdivision within the main lineage.

The final major lineage to be established in the Early Jurassic is the imbricating placolith group, appearing in the late Pliensbachian. Contrasting with the last group, which was important and successful in its great diversity of form, the imbricating placolith group was important in producing the numerically dominant genera *Lotharingius*, *Ellipsagelosphaera* and *Watznaueria* which often dominated coccolith assemblages for the rest of the Jurassic.

Although any attempt to propose inter-lineage relationships at this stage would be speculative due to the lack of coccoliths showing intermediate structures,

it is possible to propose a number of reasonable hypotheses which would account for their origins.

The loxolith rim and the protolith rim structures possess analogous component parts in their construction and the division between them is based solely on the imbrication or non-imbrication of their outer distal cycle. Their morphological similarity therefore, suggests a close biological relationship. The two groups may have shared a common ancestor in the Triassic or alternatively one of the two groups may have formed the ancestral lineage from which the other developed. The reason why these have not yet been discovered could be a result of the extremely small size of coccoliths in the Upper Triassic. However, a relatively sudden appearance of coccoliths in the Late Triassic may simply reflect a calcification event in which a previously naked group of organisms developed calcite scales, allowing their preservation in the fossil record. Fig. 4 shows the arrangement of the Lower Jurassic species along the respective lineages.

The radiating placolith group may also have appeared due to the calcification of a previously naked lineage of coccolithophores or it may have developed as a branch from one of the two existing lineages. Although both the loxolith and protolith rims possess the potential for the development of the placolith structure no coccoliths possessing convincing intermediate structures have yet been found.

As for the appearance of the imbricating placolith group, a further permutation is added to the possibilities with development conceivable from any of the three existing lineages. The change from the radiating placolith structure involves the least radical structural re-organisation and there is some evidence to support such a link. In the Mochras borehole section, for instance, the appearance of *Biscutum* in the Jamesoni Zone is followed in the subsequent zones by the appearance of larger radiating placoliths which display a tendency towards element imbrication while retaining the basic structure of the lineages. However, the suture precession displayed by these forms and by *Biscutum* itself appears to be in the opposite direction to that seen in *Lotharingius* (the first imbricating placolith genus to appear) and only a development similar to that shown to occur in the genus *Ericsonia* by ROMEIN (1979, p. 68) could successfully explain such a reversal of suture precession.

Once established in the Early Jurassic, these four major lineages provided the basis for all later Jurassic structural diversification. Those developments which appeared in the Pliensbachian to Early Toarcian diversification are listed as follows and illustrated in Fig. 5.

Protolith rim group

1) *Stradnerlithus*

Lowering of the protolith rim involving a reduction of the distal shield to a single cycle of "cuboid" elements.

2) *Stephanolithion*

A development similar to that in *Stradnerlithus* but additionally involving the formation of distinctive elements in the rim (giving the upper surface of the distal shield a "zig-zag" appearance). A number of elements also form the lateral spines so characteristic of the genus.

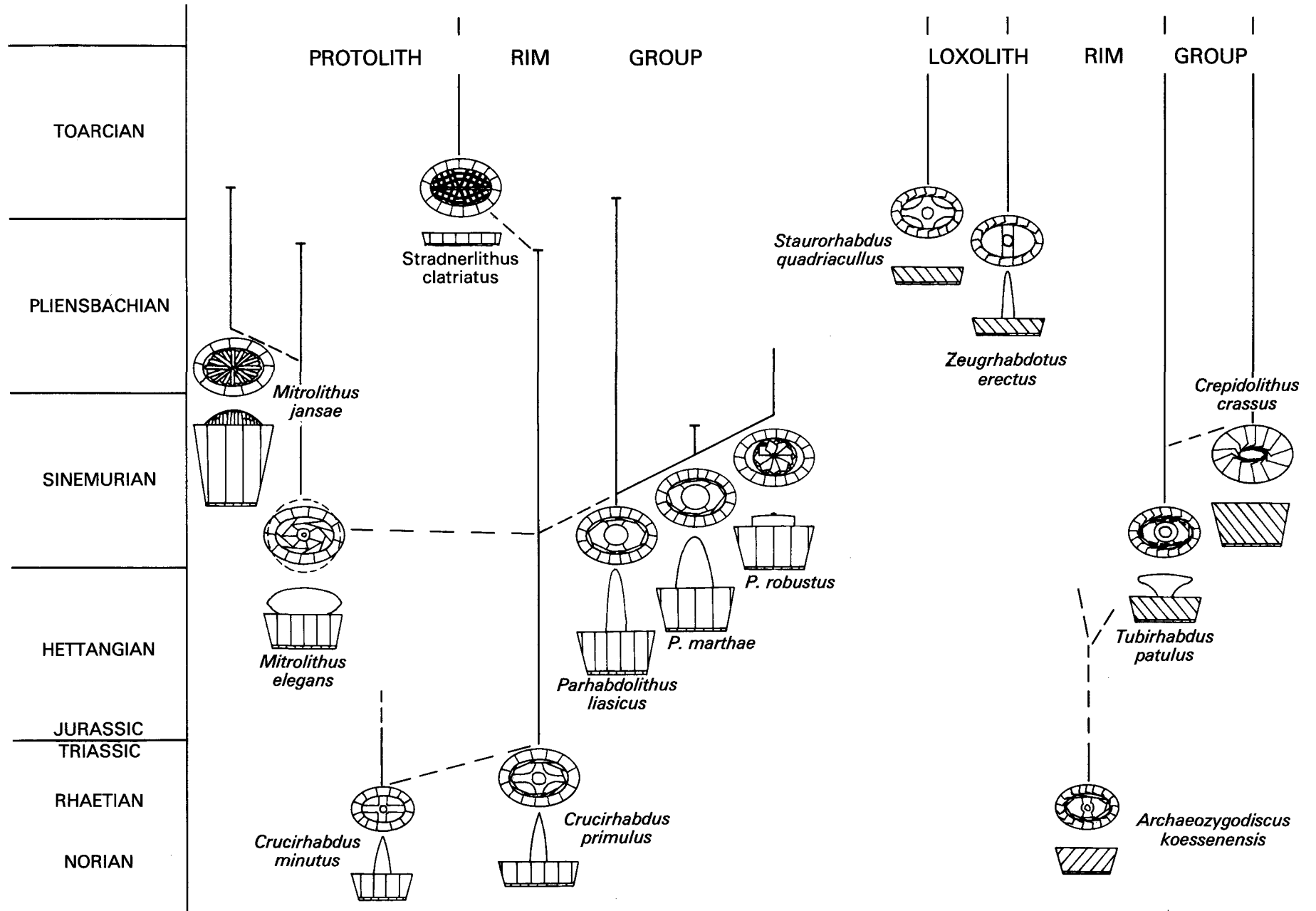

Fig. 4.: Stratigraphic distribution and suggested evolutionary relationships within the loxolith and protolith rim structure groups.

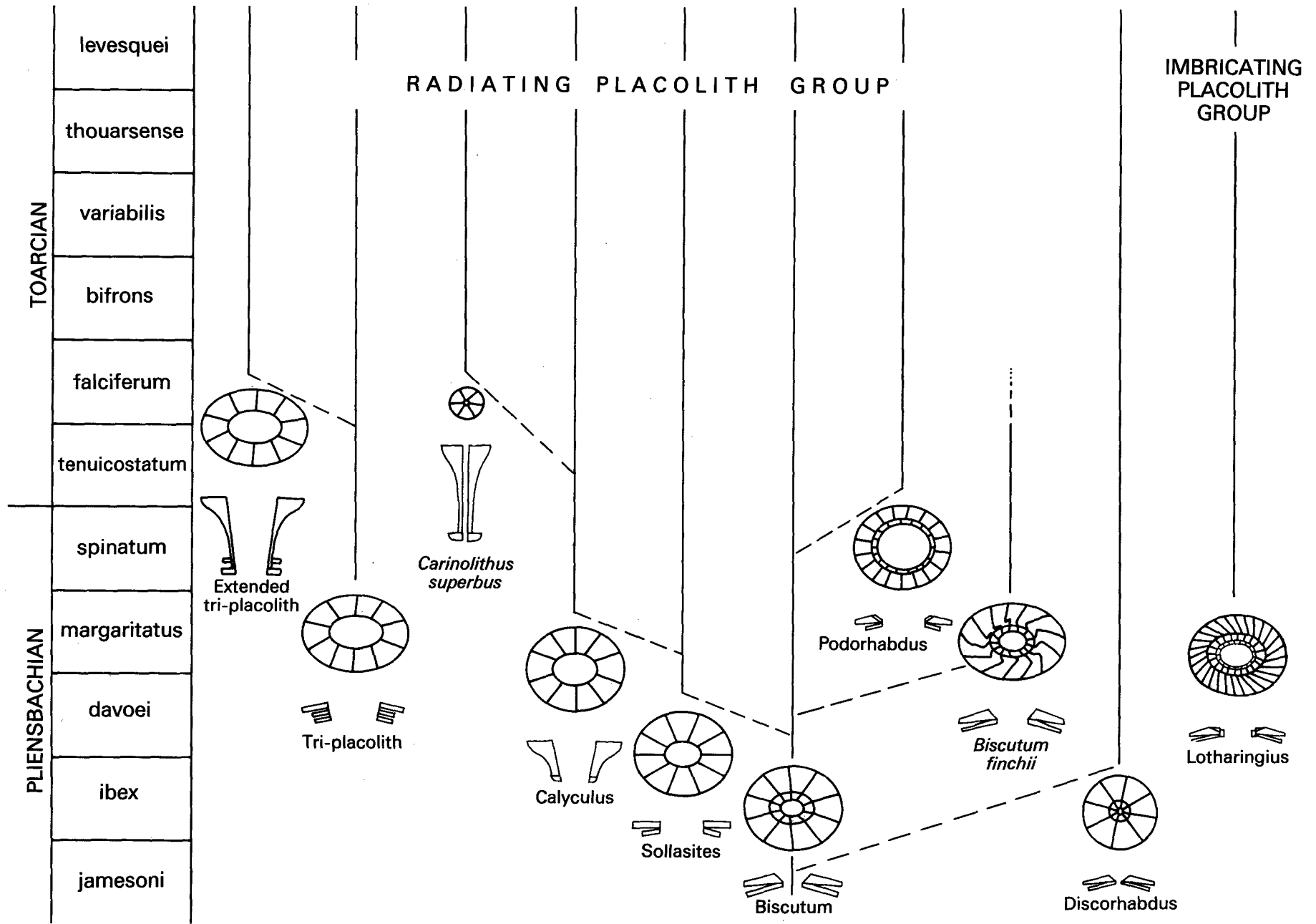

Fig. 5: Structural diversification and suggested evolutionary relationships within the radiating placolith and imbricating placolith rim structure groups.

Radiating Placolith rim group

3) *Biscutum*

Addition of an inner distal cycle of elements which lines the sloping central area.

4) *Discorhabdus*

The development of a circular coccolith shape.

5) *Podorhabdus*

A Progression from group (3) with the opening out of the rim, to form the distinctive rim of the podorhabdids with a large central area.

6) *Calyculus*

A vertical extension of the distal shield elements, and reduction of the proximal shield to a simple ring of small elements.

7) *Carinolithus*

A progression from the last group (6) involving the extreme extension of the distal shield elements, a reduction of the coccolith diameter, and the development of a circular coccolith shape.

8) Tri-placolith rim

A development involving the addition of a third cycle to the basic two shield placolith structure.

Imbricating Placolith rim structure

9) *Lotharingius* / *Ellipsagelosphaera*

The basic imbricating placolith rim structure is shared by both these important genera. Further modifications produce the genera *Watznaeria*, *Cyclogelosphaera* and *Ansulosphaera*.

7. Comparison with Earlier Studies

PRINS (1969) outlined seven evolutionary lineages all originating from the single coccolith species *Crucirhabdus primulus*, which he observed from the Rhaetian. The study suffers from a lack of scanning electron microscope work on the coccoliths and the consequent lack of information about the differing coccolith rims present. Thus, PRINS' lineages are based on morphological similarities observed in the light microscope and the order in which the coccoliths appeared through the Lower Jurassic. The first two proposed lineages are speculative attempts to link the radiating and imbricating placoliths groups of the present study to earlier coccoliths; and his third and fifth lineages are confirmed here. The major difference between PRINS' scheme and the present proposal is therefore his assumption that all developments came from one Triassic species, whereas it is known that two distinct lineages are present in Triassic.

JAFAR (1983) formed no overall scheme but suggested certain lineages and offered a critique of PRINS' evolutionary scheme based on his own observation from the Upper Triassic. JAFAR also lacked scanning electron microscope information and his suppositions are often speculative. For example, JAFAR suggests that the genera *Crepidolithus* and *Carinolithus* are not related to genuine coccoliths but to an enigmatic group of calcitic bodies which occur in great numbers in some Triassic rocks and which he named *Prinsiosphaera*. However, both these genera have the ultrastructure of true coccoliths and possess coccolith rims which fit well into the lineages proposed in this paper. The *Prinsiosphaera* group of nanofossils JAFAR describes have no such well-organised structure and do not seem in any way related to true coccoliths.

It should also be noted here that JAFAR's (1983) record of "one badly preserved specimen of *Vekshinella thiersteinii*, one broken specimen of *Palaeopontosphaera repleta* and one specimen of *Ellipsochiastus primitus*" cannot be substantiated from the present study.

8. Coccolith Taxonomy

Taxonomy is the classification of individual forms by recognising relationships between them (in this case based on morphological similarity) and their subsequent division into hierarchical groups reflecting varying levels of kinship or likeness. The aim of palaeontological taxonomy is a "usable" classification which reflects as closely as possible the biological relationships which exist between organisms.

The present study covers a period of geological time when the combination of relatively few coccolith species and simple patterns of construction allows a clear and effective grouping of the coccoliths using their distinctive rim structures. Such a division would seem to conform closely to that of the Family in the Lower Jurassic but ultimately to ordinal level. The four structural groups may be thought of as Families, viz.

- 1) Ioxolith rim structure group – Family Zygodiscaceae (HAY & MOHLER 1967)
- 2) Protolith rim structure group – Family Parhabdolitheaceae nov. fam.
- 3) Radiating placolith rim structure group – Family Biscutaceae (BLACK 1971)
- 4) Imbricating placolith rim structure group – Family Ellipsagelosphaeraceae (NOËL 1965)

Coccolith rim structure is of fundamental importance in the taxonomy of coccoliths and detailed scanning electron microscope observation is as important as light microscopy in such studies. This point may be clarified using the genus *Parhabdolithus* as an example. *Parhabdolithus* was erected by DEFLANDRE (1952) using *Parhabdolithus liasicus* as type species and also including *Parhabdolithus marthae*. Both of these species possess a protolith rim as described in this paper. Subsequently other species have been assigned to this genus, presumably using similarities of morphology observed in the light microscope, however, many of these taxa when observed in the scanning electron microscope are seen to possess completely different rim structures to those originally assigned to the genus by DEFLANDRE. Such a species is the well-known *Parhabdolithus embergeri*, which possesses a very distinctive Ioxolith rim and clearly belongs in a separate genus, probably *Zeugrhabdotus*.

9. Conclusion

Study of Late Triassic and Early Jurassic coccoliths has revealed the presence of natural divisions within the forms studied which allow the recognition of "evolutionary" lineages through time, defined by their characteristic rim structures. Four such structure groups are established by the Upper Pliensbachian and these form the basis for the further structural develop-

ments which occur progressively through the Jurassic. It is thought that these groupings conform closely to the division of Family and it is therefore important to include detailed structural analysis of the coccolith rim in any study involving evolutionary and taxonomic proposals.

10. Systematic Palaeontology

Family Parhabdolithaceae fam. nov.

Diagnosis: Coccoliths with a protolith rim structure i.e. a rim typically consisting of

- dominant and characteristic distal shield composed of laths arranged vertically to subvertically and tangentially to an ellipse with sutures perpendicular to the coccolith base

and

- a proximal shield composed of elements with a triangular cross-section which form a flat coccolith base with radiating sutures and also extend upwards to form an inner cycle to the distal shield (see Fig. 2).

The Family Parhabdolithaceae includes the genera *Crucirhabdus*, *Mitrolithus* and *Parhabdolithus*. The genera *Stradnerlithus* and *Stephanolithion* have a modified protolith rim structure which warrants grouping into a separate family, the Stephanolithiaceae (BLACK, 1968).

Remarks: The Subfamily Parhabdolithoideae erected by GARTNER (1968) was defined to include genera processing loxolith rim structures, based on the misconception that *Parhabdolithus* typified loxolith construction. The Family Apertiaceae erected by GOY (1981) is unavailable as it is based on a coccolith which is a junior synonym of *Crucirhabdus primulus*. The Family Crepidolithaceae (BLACK 1971a) is not used due to the problematic nature of the type genus *Crepidolithus* which contains coccoliths with predominantly loxolith rims.

Genus *Mitrolithus* DEFLANDRE (1954)

emend. BOWN & YOUNG 1986

in YOUNG et al. 1986

(Pl. 3, figs. 1–3)

Type species: *Mitrolithus elegans*

Emended diagnosis: Coccoliths possessing a protolith rim and a central area filled with a massive boss or spine consisting of several superimposed cycles of radial calcite elements. The spine sits in the coccolith rim on the well developed vertical extension of the proximal shield and is attached via a narrow, hollow spine base.

Remarks: DEFLANDRE erected the genus *Mitrolithus* in 1954 and defined it as "a bowl shaped discolith with a central area possessing a massive, flaring protuberance of mushroom-shaped style, giving the lateral view the appearance of a Bishops mitre". The emended diagnosis introduces ultrastructural details into the original description and also removes the imprecise similes. The generic definition includes both *M. elegans* and *M. jansae*.

Mitrolithus jansae (WIEGAND 1984)

BOWN & YOUNG 1986

in YOUNG et al. 1986

(Pl. 3, fig. 4)

1969 *Mitrolithus irregularis* n. sp. PRINS; Pl. 1, fig. 12

1984 *Calcivascularis jansae* n. gen. n. sp. WIEGAND; p. 1151, Pl. 1, figs A–C

Description: The diagnosis and description given in WIEGAND (1984) is comprehensive and no addition is necessary. However, it is useful to note the great variation encountered in the relative dimensions of the coccolith rim and spine but this does not necessitate modification of the diagnosis.

Remarks: *Mitrolithus* as described by DEFLANDRE (1954) remained monospecific until 1969 when PRINS figured the species "irregularis" and attributed it to *Mitrolithus*. Unfortunately PRINS omitted a written diagnosis and description thus creating a *nomen nudum*. The species remained neglected until Wiegand (1984) described and illustrated a new genus and species under the name *Calcivascularis jansae*. Although the specific name *jansae* stands as the first formal description of the coccolith, the genus *Calcivascularis* is a synonym of *Mitrolithus*.

Differences: Both *M. elegans* and *M. jansae* are usually observed in side view and the light microscope sketches of PRINS (1969) clearly reveal their distinguishing characters. *M. jansae* commonly possesses a higher rim than *M. elegans*, often entirely enclosing its own spine which is parallel-sided compared to the flaring spine of *M. elegans*.

Genus *Parhabdolithus* DEFLANDRE 1952

emend. BOWN

Type species: *Parhabdolithus liasicus*

Emended diagnosis: Coccoliths with a high protolith rim and a central area bearing a spine which may vary greatly in diameter and height. The spine is borne on a bar or basal plate and has an axial canal.

Remarks: The genus includes the species *P. liasicus*, *P. marthae* and *P. robustus*, individually defined on the varying parameters of spine shape, diameter and height.

Parhabdolithus robustus NOËL 1965

(Pl. 1, figs. 5,6; Pl. 2, figs. 8,9)

Remarks: The central area is entirely filled by a short, broad spine which terminates bluntly without tapering. The spine has a diameter greater than half the width of the coccolith base and terminates at or just above the coccolith rim but usually to a height no greater than twice that of the rim itself. The spine is composed of 8–15 intergrown columnar calcite rhombs and is terminated by a ring of tiny crystals surrounding a central canal. Very distinctive in the light microscope. Often abundant in the Sinemurian and lower Pliensbachian.

Range: turneri Zone to ibex Zone.

Family Biscutateae BLACK 1971

Genus *Biscutum* BLACK

in BLACK & BARNES 1959

Type species: *Biscutum testudinarium*

***Biscutum finchii* CRUX 1984
emend. BOWN**

(Pl. 2, figs. 3,4,10,11)

Original diagnosis: "A species of *Biscutum* with a large central area and no spine" (CRUX, 1984, p. 168).

Emended diagnosis: A large elliptical species of *Biscutum* with a modified radiating placolith structure. The distal shield is composed of non-imbricating elements with a gentle outer slope forming the shield and an inner edge producing a deep central area. The sutures are sharply kinked at the point from which the elements slope and they also have a slight anticlockwise precession due to the kinking. The proximal shield is only slightly smaller than the distal shield; its elements are non-imbricating with sutures only slightly deviating from the radial pattern. The central area is vacant or filled with granular elements. In the light microscope, phase-contrast and crossed polars, the large shield appears dark and the individual elements are clearly defined. The central area may appear as a rounded cross shape.

Range: margaritatus Zone to tenuicostatum Zone.

***Biscutum novum* (GOY, 1979) n. comb.
(Pl. 2, figs. 1,2)**

1979 *Palaeopontosphaera nova* GOY; p. 52, Pl. 19, figs. 4-7; Pl. 20, figs. 1,2; Fig. 12.

Remarks: The earliest representative of *Biscutum* in the Lower Jurassic, *B. novum*, is differentiated from *B. dubium* by its larger size and unicyclic distal shield.

Acknowledgements

I would like to thank Dr. A. R. LORD for his help and supervision throughout this study and to M. PEARSON, R. THOMPSON, Dr. M. URLICHS and Dr. T. STEIGER for their assistance during the collection of study material. Also thanks to Dr. J. CRUX and J. YOUNG for helpful discussions. This work was supported by a Natural Environment Research Council Research Studentship, which is gratefully acknowledged.

References

- BARNARD, T. & HAY, W. W.: On Jurassic Coccoliths: A tentative zonation of the Jurassic of Southern England and North France. — *Eclogae geol. Helv.*, **67**, 563-585, 6 pls., Basle 1974.
- BLACK, M.: Taxonomic problems in the study of coccoliths. — *Palaeontology*, **11**, 793-813, London 1968.
- BLACK, M.: Coccoliths of the Speeton Clay and Sutterby Marl. — *Yorkshire Geol. Soc. Proc.*, **38**, 381-424, Yorkshire 1971.

- BLACK, M.: British Lower Cretaceous Coccoliths. I. Gault Clay. — *Pal. Soc. Monographs*, November, 1972, pp. 48, 16 pls., London 1972.
- BLACK, M. & BARNES, B.: The structure of coccoliths from the English Chalk. — *Geol. Mag.*, **96**, 321-328, London 1959.
- BOWN, P. R.: *Archaeozygodiscus* gen. nov. and other Triassic coccoliths. — *I.N.A. Newsletter*, **7**(1), 32-35, 1 pl., Utrecht 1985.
- CRUX, J. A.: Biostratigraphy of Early Jurassic Calcareous Nannofossils from Southwest Germany. — *N. Jb. Geol. Paläont. Abh.*, **169**(2), 160-186, 7 pls., Stuttgart 1984.
- DEFLANDRE, G.: Classe de Coccolithoporidés. — In: PIVETEAU, J.: *Traité de Paléontologie*, pp. 782, Paris 1952.
- DEFLANDRE, G. & FERT, C.: Observations sur les coccolithophoridés actuels et fossiles en microscopie ordinaire et électronique. — *Ann. Paléont.* **40**, 115-176, 15 pls., Paris 1954.
- GARTNER, S.: Coccoliths and related Calcareous nannofossils from the Upper Cretaceous Deposits of Texas and Arkansas. — *Kansas Univ. Paleont. Contr.*, Article 48 (Protista 1), pp. 56, Kansas 1984.
- GOY, G.: Nannofossiles calcaires des schistes carton (Toarcien inférieur) du bassin de Paris. — *Doc. R.C.P.*, **459**, pp. 86, 34 pls., Paris 1981.
- GRUN, W., PRINS, B. & ZWEILL, F.: Coccolithophoriden aus dem Lias epsilon von Holzmaden (Deutschland). — *N. Jb. Geol. Paläont. Abh.*, **147**, 294-328, 22 text-figs., Stuttgart 1974.
- HAMILTON, G.: Triassic and Jurassic calcareous nannofossils. — In: LORD, A. R.: *A Stratigraphical Index of Calcareous Nannofossils*, pp. 192, 27. pls., Chichester (Ellis Horewood) 1982.
- JAFAR, S. A.: Significance of late Triassic Calcareous Nannoplankton from Austria and Southern Germany. — *N. Jb. Paläont. Abh.*, **166**(2), 218-259, 7 pls., Stuttgart 1983.
- MOSHKOVITZ, S.: On the findings of a new calcareous nannofossil (*Conusphaera zlabachensis*) and other calcareous organisms in the Upper Triassic sediments of Austria. — *Eclogae geol. Helv.*, **75**(3), 611-619, 2 pls., Basle 1982.
- NOËL, D.: Sur les coccoliths du Jurassique européen et d'Afrique du Nord. Essai de classification des coccolithes fossiles. — *Edition du Centre national de la Recherche Scientifique*, pp. 209, Paris 1965.
- PRINS, B.: Evolution and Stratigraphy of Coccolithinids from the Lower and Middle Lias. — *Proc. I. Plankt. Conf.*, Geneva 1967, **2**, 547-553, 3 pls., Leiden 1969.
- ROMEIN, A. J. T.: Lineages in Early Paleogene Calcareous Nannoplankton. — *Utrecht Micropaleont. Bull.*, **22**, pp. 231, 10 pls., Utrecht 1979.
- WIEGAND, G. E.: Two new genera of calcareous nannofossils from the Lower Jurassic. — *J. Paleont.* **54**(4), 1151-1155, Kansas 1984.
- WOODLAND, A. W. (Ed.): *The Llanbedr (Mochras Farm) Borehole*. *Rep. Inst. Geol. Sci.*, **71/18**, pp. 115, London 1971.
- YOUNG, J. R., TEALE, C. T. & BOWN, P. R.: Revision of the stratigraphy of the Longobucco group (Lower Jurassic, S. Italy) based on new data from nannofossils and ammonites. — *Eclogae geol. Helv.*, **79**, 117-137, Basle 1986.

Plate 1

- Figs. 1 & 2: *Crepidolithus crassus* (DEFLANDRE in DEFLANDRE & FERT 1954) NOËL 1965
1. UCL-1916-24; distal view, $\times 11,200$.
2. UCL-1916-23; oblique view of 1.1., $\times 11,200$.
- Figs. 3 & 4: *Tubirhabdus patulus* PRINS in ROOD, HAY & BARNARD 1973
3. UCL-2014-4; distal view, $\times 15,200$.
4. UCL-2014-5; oblique view of 6.3, $\times 15,200$.
- Figs. 5 & 6: *Parhabdolithus robustus* NOËL 1965
5. UCL-2072-3; distal view, $\times 13,000$.
6. UCL-2075-5; lateral view of 1.5, $\times 13,000$.
- Figs. 7 & 8: *Parhabdolithus liasicus* DEFLANDRE 1952
7. UCL-1916-15; distal view, $\times 13,700$.
8. UCL-1916-14; oblique view of 1.7, $\times 13,700$.

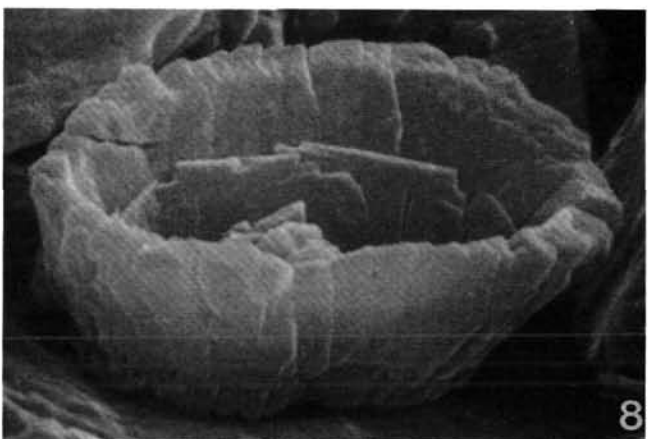
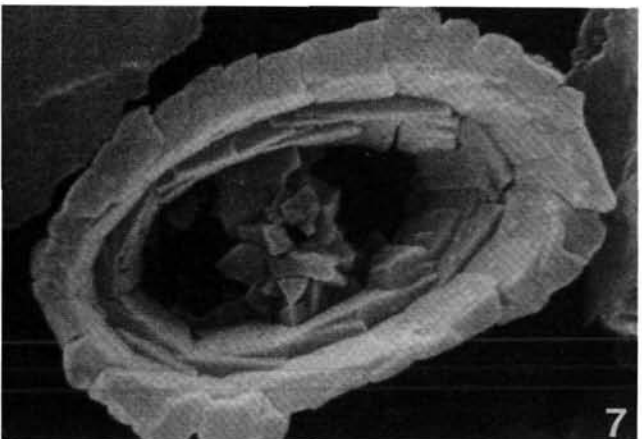
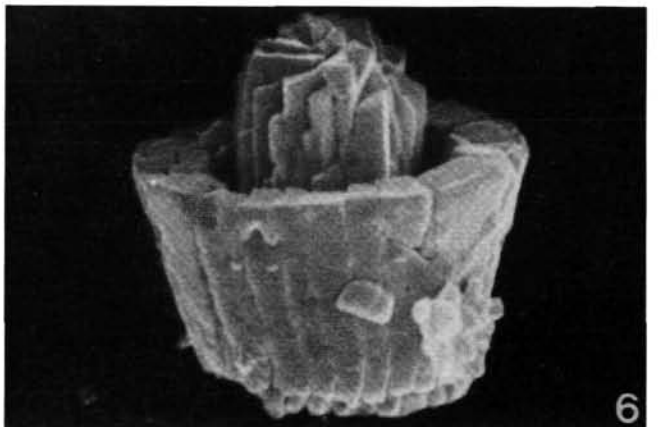
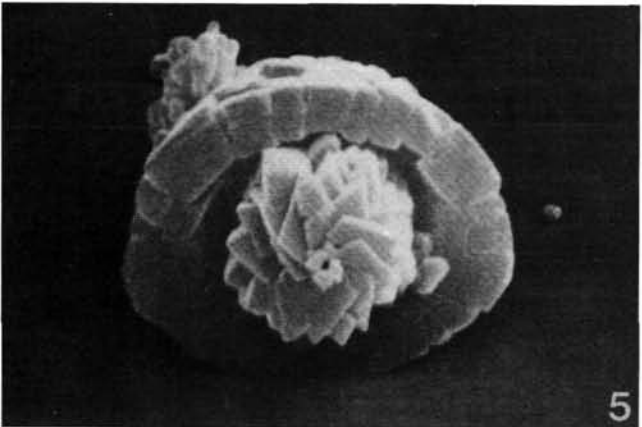
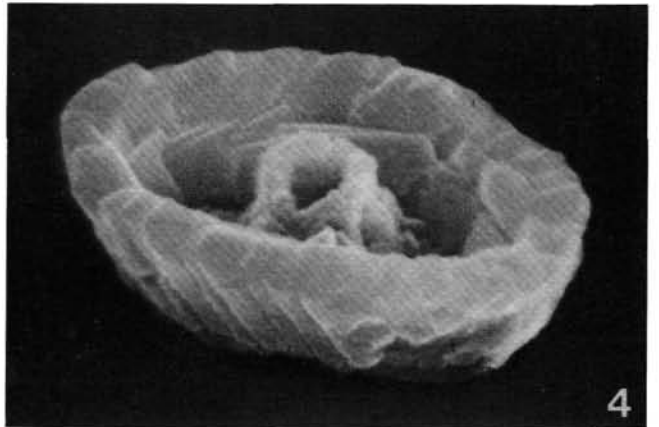
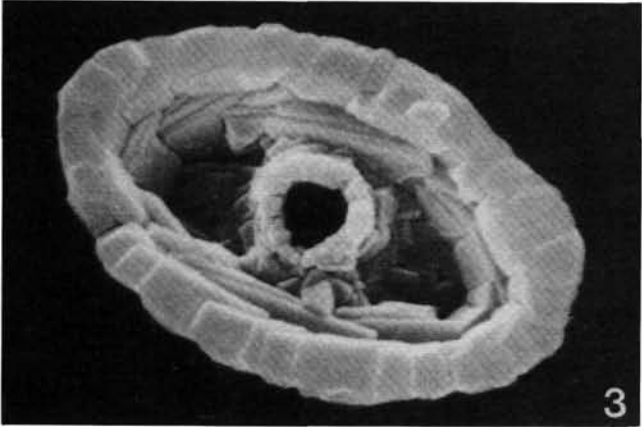
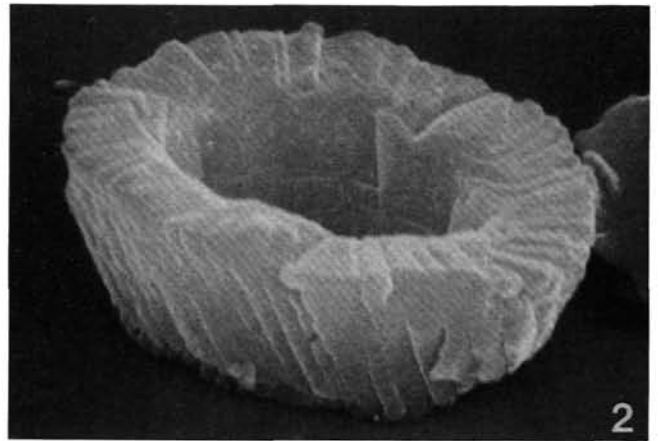
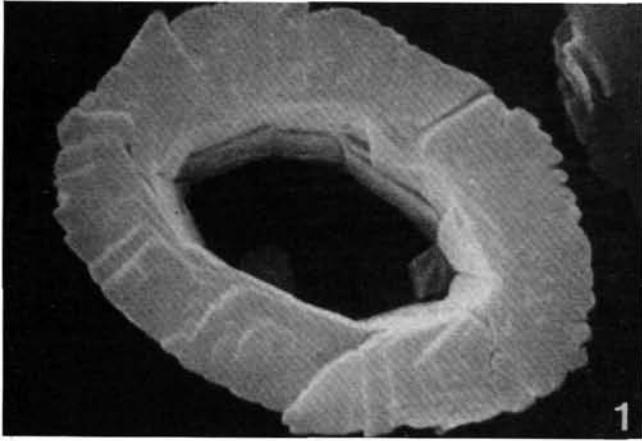

Plate 2

- Figs. 1 & 2: *Biscutum novum* (GOY 1979) n. comb.
1. UCL-1952-19; distal view, $\times 14,700$.
2. UCL-2074-17; proximal view, $\times 13,300$.
- Figs. 3 & 4: *Biscutum finchii* CRUX 1984 emend.
3. UCL-2147-24, distal view, $\times 8,100$.
4. UCL-2147-13 proximal view, $\times 10,000$.
- Figs. 5,6 & 7: *Lotharingius sigillatus* (STRADNER 1961) PRINS 1974
5. UCL-2007-15; distal view, $\times 12,500$.
6. UCL-2007-17; proximal view, $\times 11,600$.
7. UCL-2007-16; oblique view of 2.5, $\times 12,500$.
- Figs. 8 & 9: *Parhabdolithus robustus* NOËL 1965
8. Phase contrast, UCL-2093-10; $\times 5,200$.
9. \times Nicols, UCL-2093-9; $\times 5,200$.
- Figs. 10 & 11: *Biscutum finchii* CRUX 1984 emend.
10. Phase contrast, UCL-2134-15; $\times 2,714$.
11. \times Nicols, UCL-2134-16; $\times 2,714$.

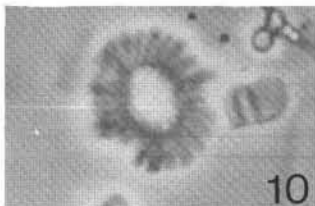
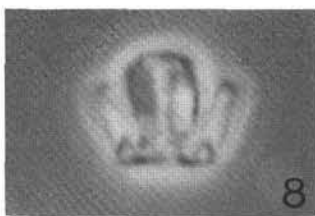
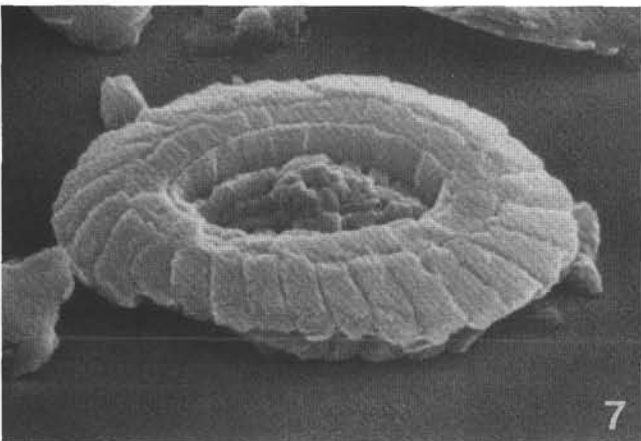
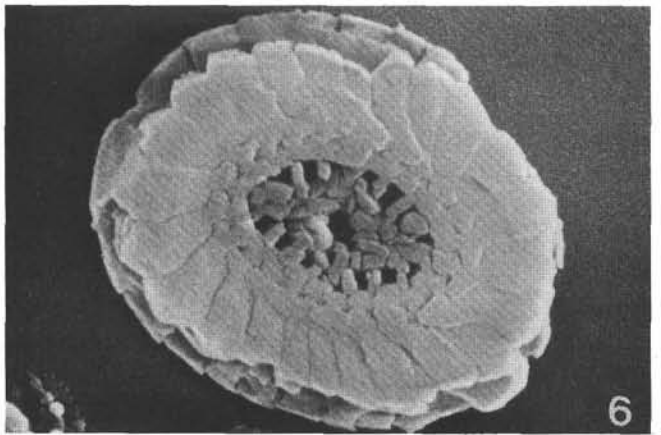
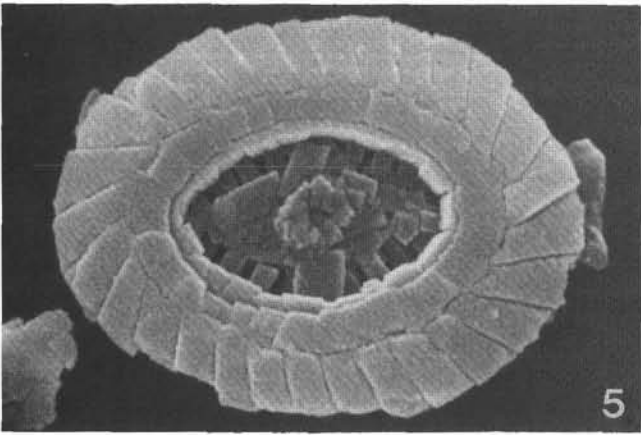
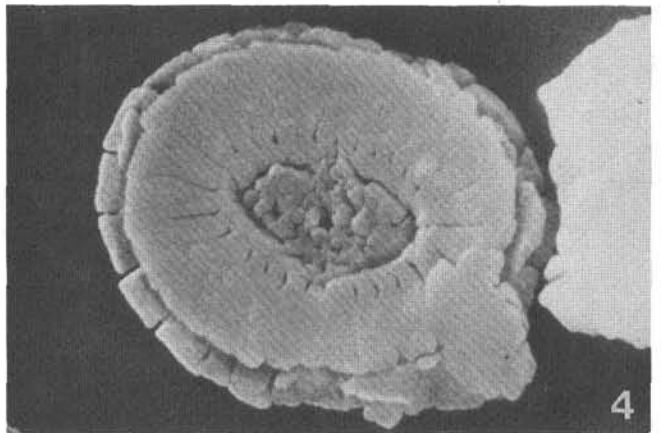
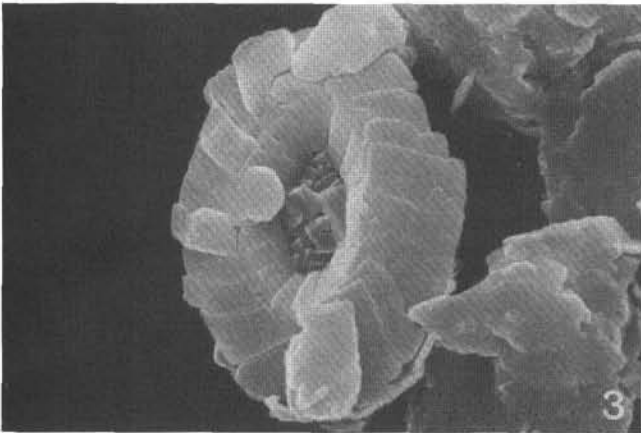
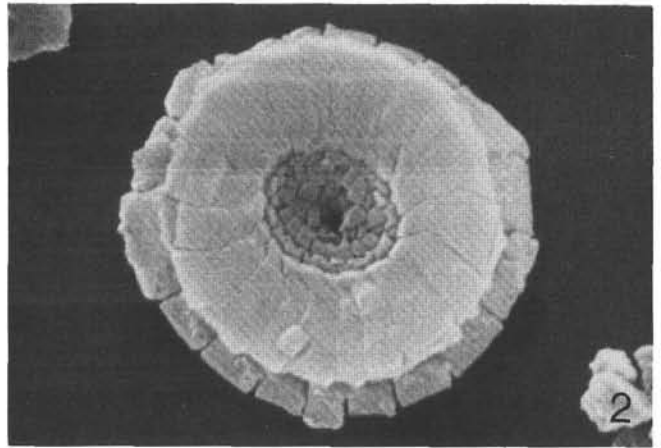
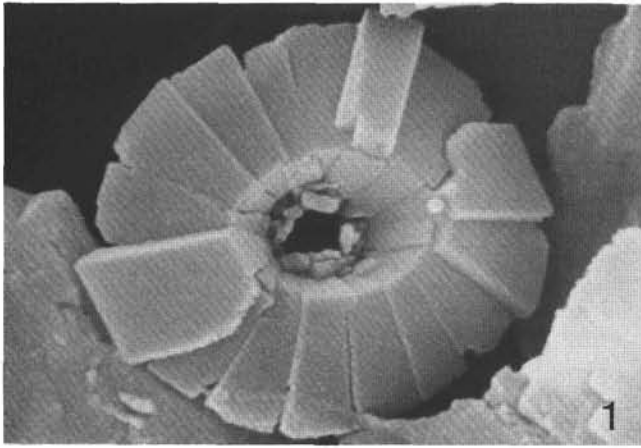

Plate 3

- Figs. 1,2 & 3: *Mitrolithus elegans* DEFLANDRE in DEFLANDRE & FERT 1954
1. UCL-2097-21; distal view without spine, × 10,300.
2. UCL-2097-20; oblique view of 3.1, × 10,300.
3. UCL-2097-26, lateral view with spine, × 8,900.
- Fig. 4: *Mitrolithus jansae* (WIEGAND, 1984) BOWN & YOUNG 1986
4. UCL-2046-36, lateral view, × 14,500.
- Figs. 5 & 6: *Calyculus* sp.
5. UCL-2034-7; proximal view, × 7,000.
6. UCL-2034-8; oblique view of 3.5, × 7,000.
- Figs. 7 & 8: *Carinolithus superbus* (DEFLANDRE 1954) PRINS 1974
7. UCL-1993-23, lateral view, × 7,700.
8. UCL-2049-26, distal view, × 10,900.

